

CHAPTER 2. – STANDARD ELEMENTS

QUOIN PANELS

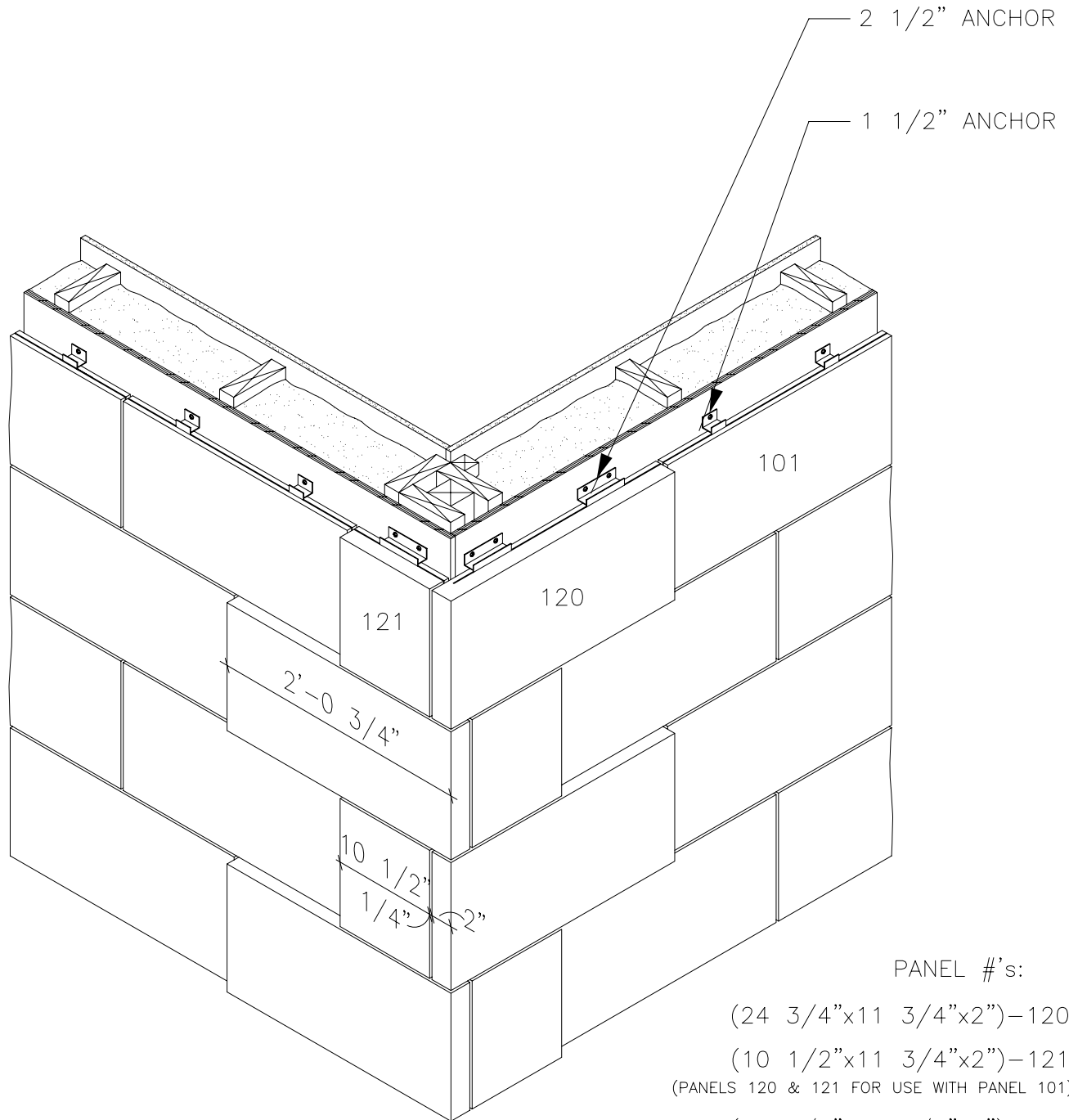

PANEL #'s:

(24 3/4"x11 3/4"x2")-120

(10 1/2"x11 3/4"x2")-121
(PANELS 120 & 121 FOR USE WITH PANEL 101)

(32 3/4"x15 3/4"x2")-122

CUT IN FIELD (14 1/2"x15 3/4"x2")-123
(PANELS 122 & 123 FOR USE WITH PANEL 150)



QUOINED CORNER DETAIL

REFERENCE 3.1.15

AMERICAN LIMESTONE COMPANY

A TEXAS CORPORATION
WWW.AMERICANLIMESTONE.COM
INFO@AMERICANLIMESTONE.COM

QUOINED CORNER DETAIL - 120, 121, 122 & 123

2.1.1



Quoined Corner
(See p. 2.1.1 of
ALC Solution Manual)

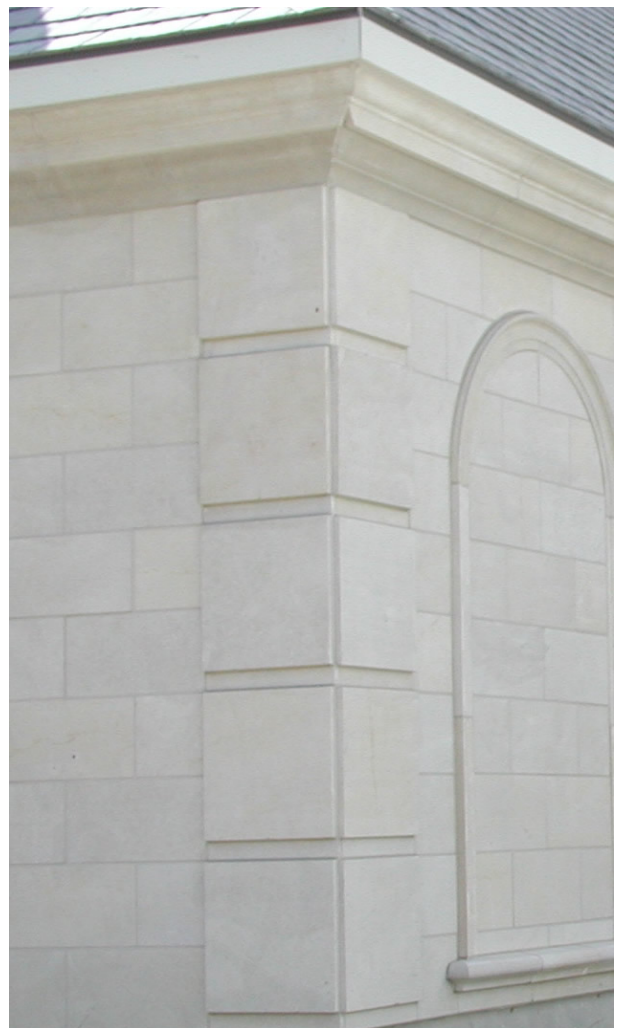

Quoin 126
(See p. 2.1.2 of
ALC Solution Manual)

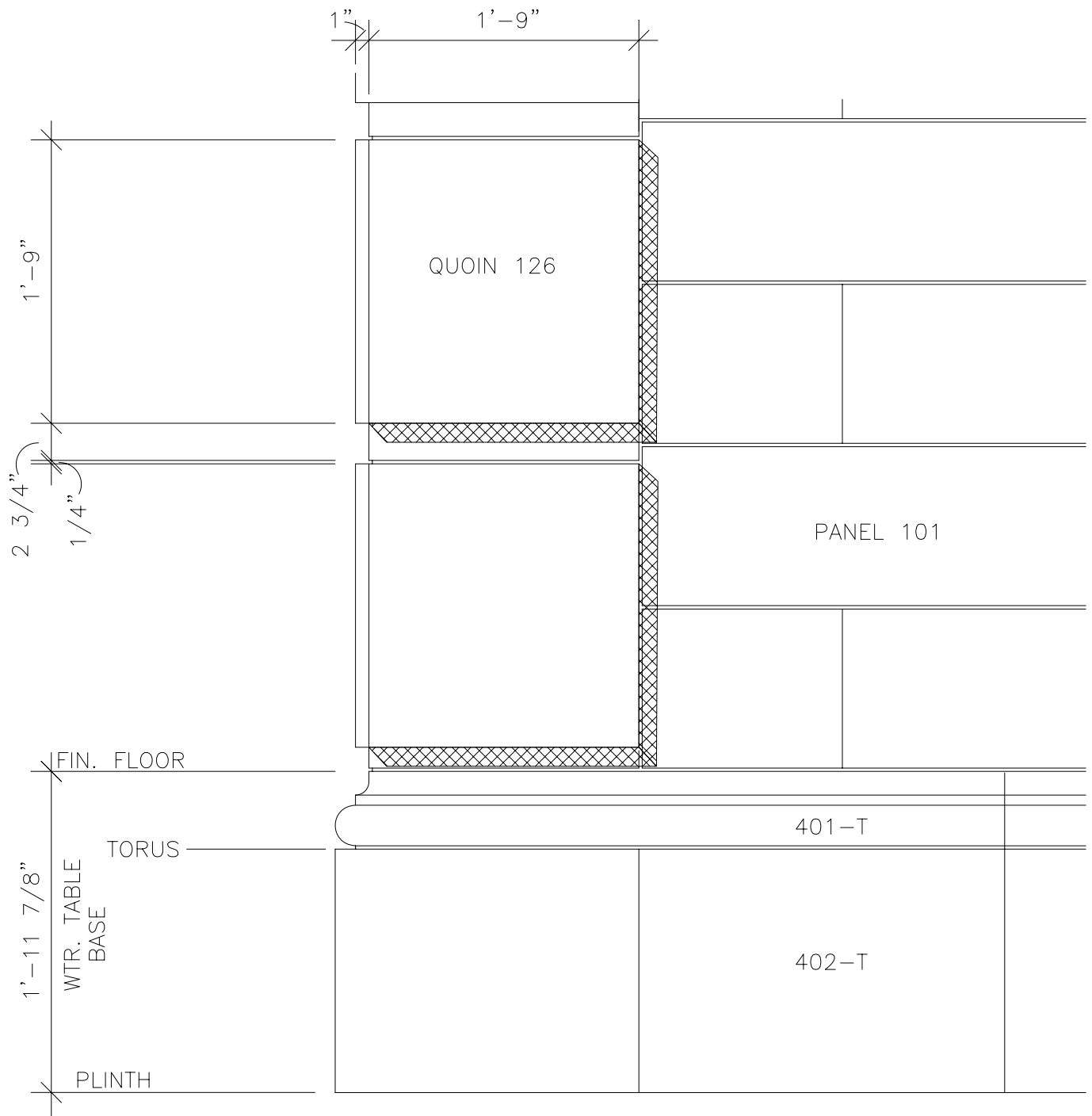

1

TUSCAN ELEVATION – 126 QUOIN

REFERENCE 3.1.16, 3.1.17, 3.1.27

AMERICAN LIMESTONE COMPANY
 A TEXAS CORPORATION
 WWW.AMERICANLIMESTONE.COM
 INFO@AMERICANLIMESTONE.COM

TUSCAN ELEVATION – 126 QUOIN

2.1.2

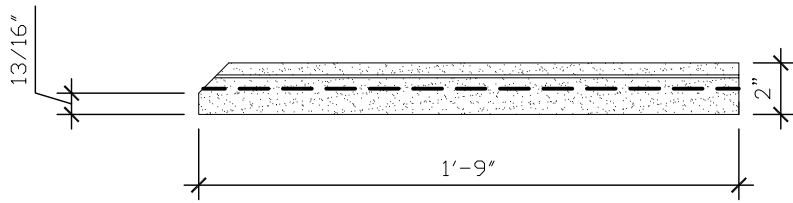

① QUOIN 126 – Top View

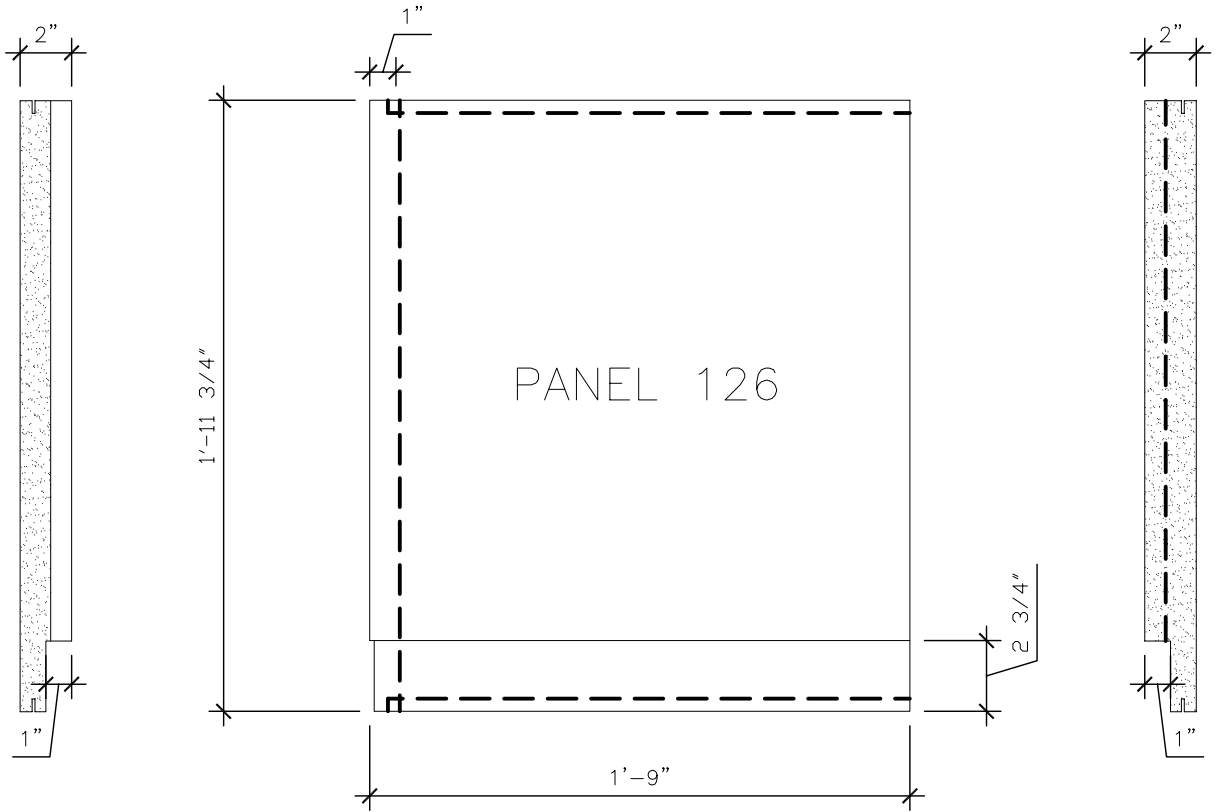

② LIMESTONE QUOIN – FACE
REFERENCE 2.1.2, 3.1.16, 3.1.17

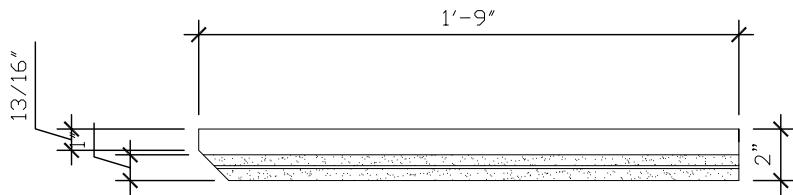

① QUOIN 126 – Bottom View

AMERICAN LIMESTONE COMPANY
A TEXAS CORPORATION
WWW.AMERICANLIMESTONE.COM
INFO@AMERICANLIMESTONE.COM

QUOIN 126 – 1'-9" x 1'-9" (NOMINAL)

2.1.3