

CLADDING/STANDARD PANELS

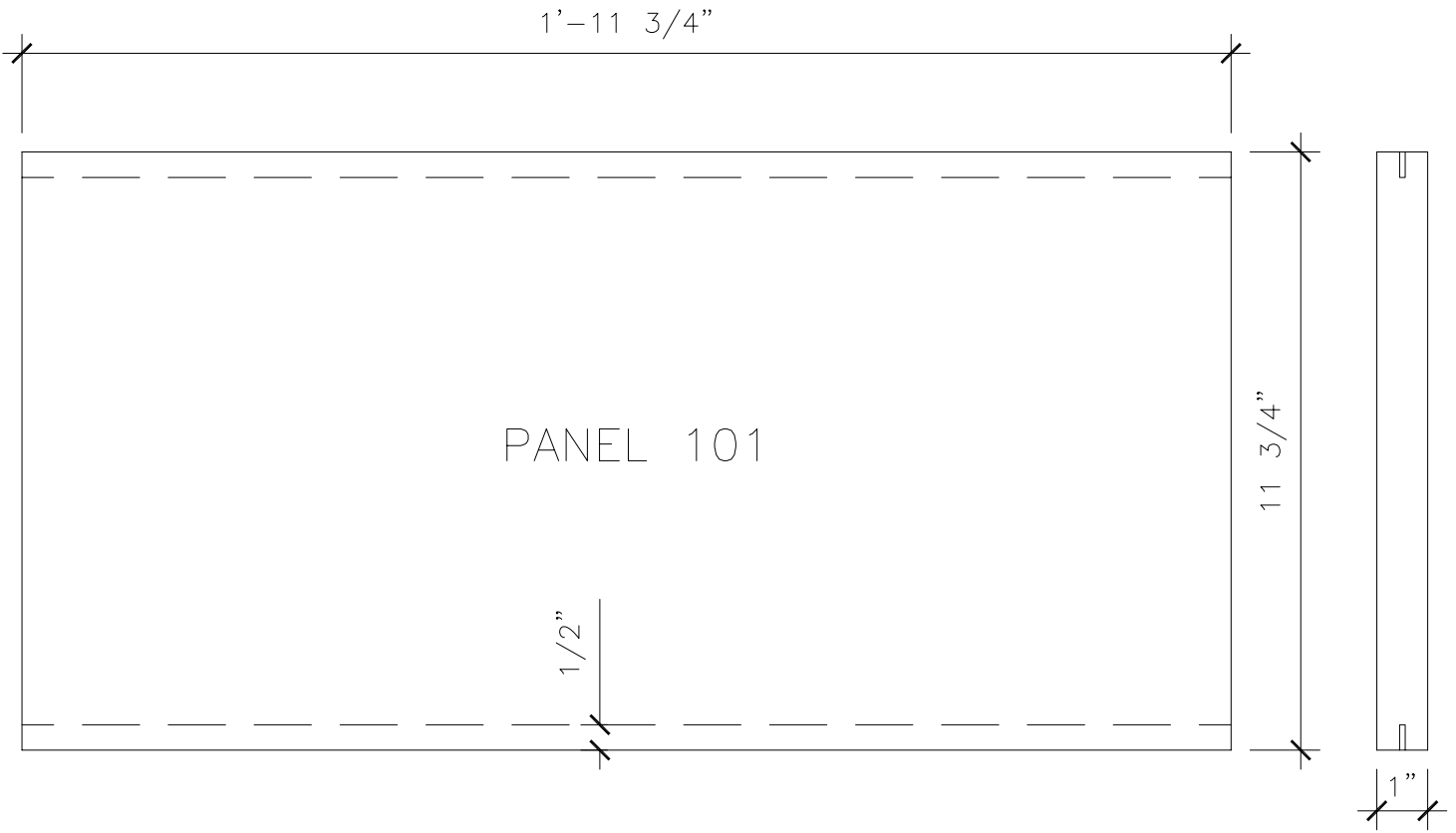

1 PANEL 101 - FACE

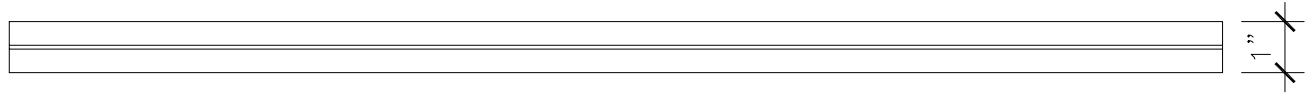

2 PANEL 101 - EDGE

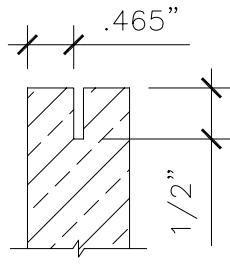

3 DETAIL - ANCHOR SLOT

AMERICAN LIMESTONE COMPANY
 A TEXAS CORPORATION
 WWW.AMERICANLIMESTONE.COM
 INFO@AMERICANLIMESTONE.COM

PANEL 101 - 24"x12" (NOMINAL)
 SCALE: NTS

2.6.1



Panel 101
(see p. 2.6.1 of
ALC Solution Manual)

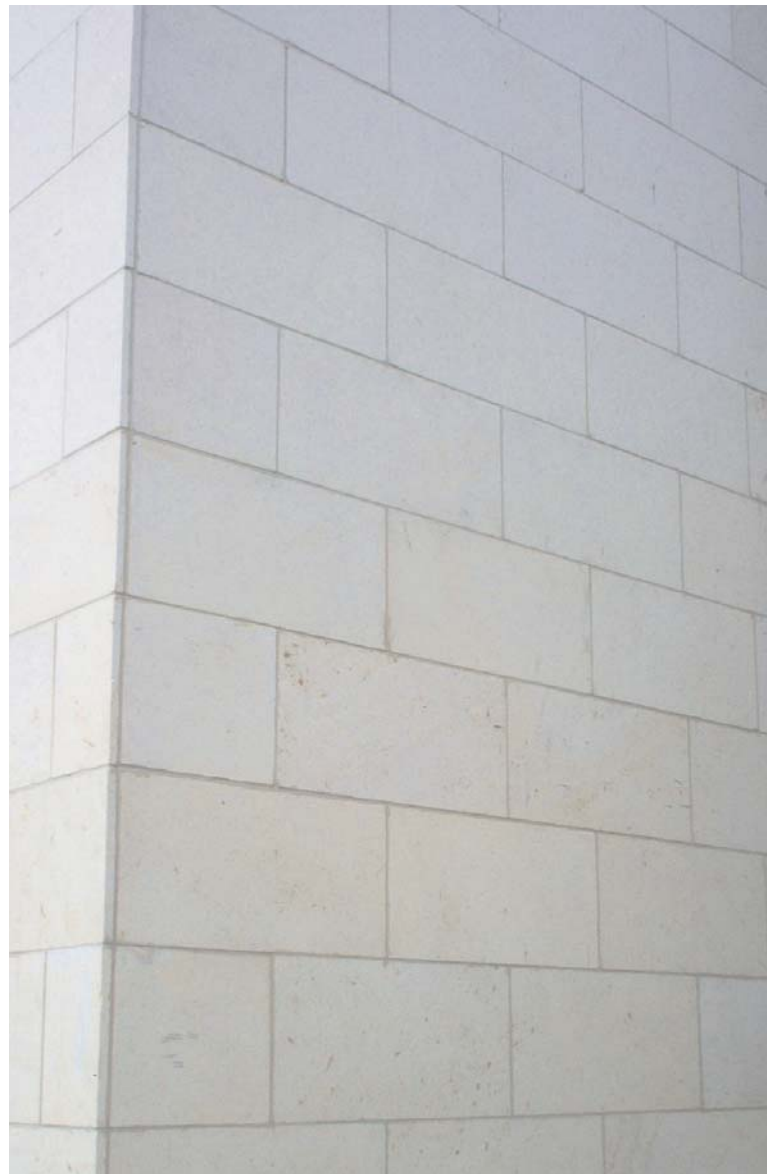

Panel 150 &
Thru-Panel Corner
(see p. 2.6.2 & 2.6.5 of
ALC Solution Manual)

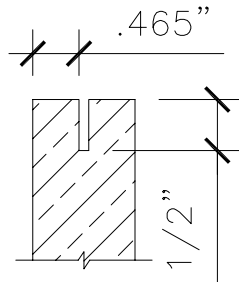
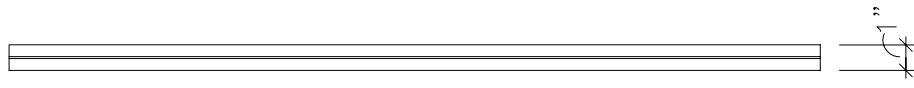
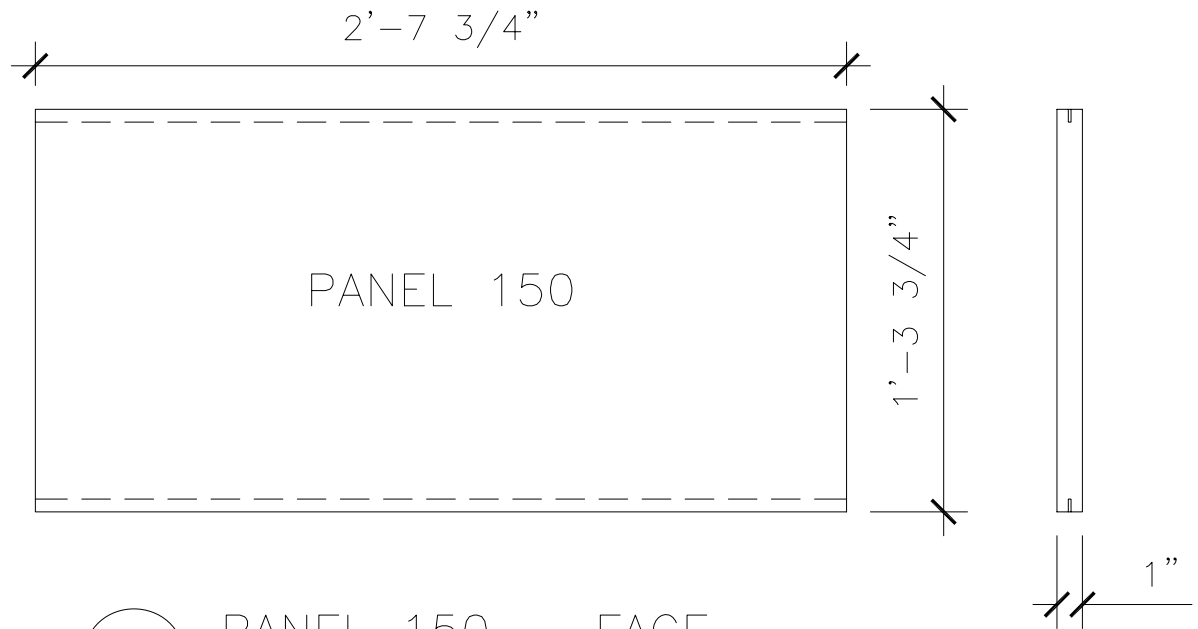

AMERICAN LIMESTONE COMPANY
 A TEXAS CORPORATION
 WWW.AMERICANLIMESTONE.COM
 INFO@AMERICANLIMESTONE.COM

PANEL 150 - 32"x16" (NOMINAL)
 SCALE: NTS

2.6.2

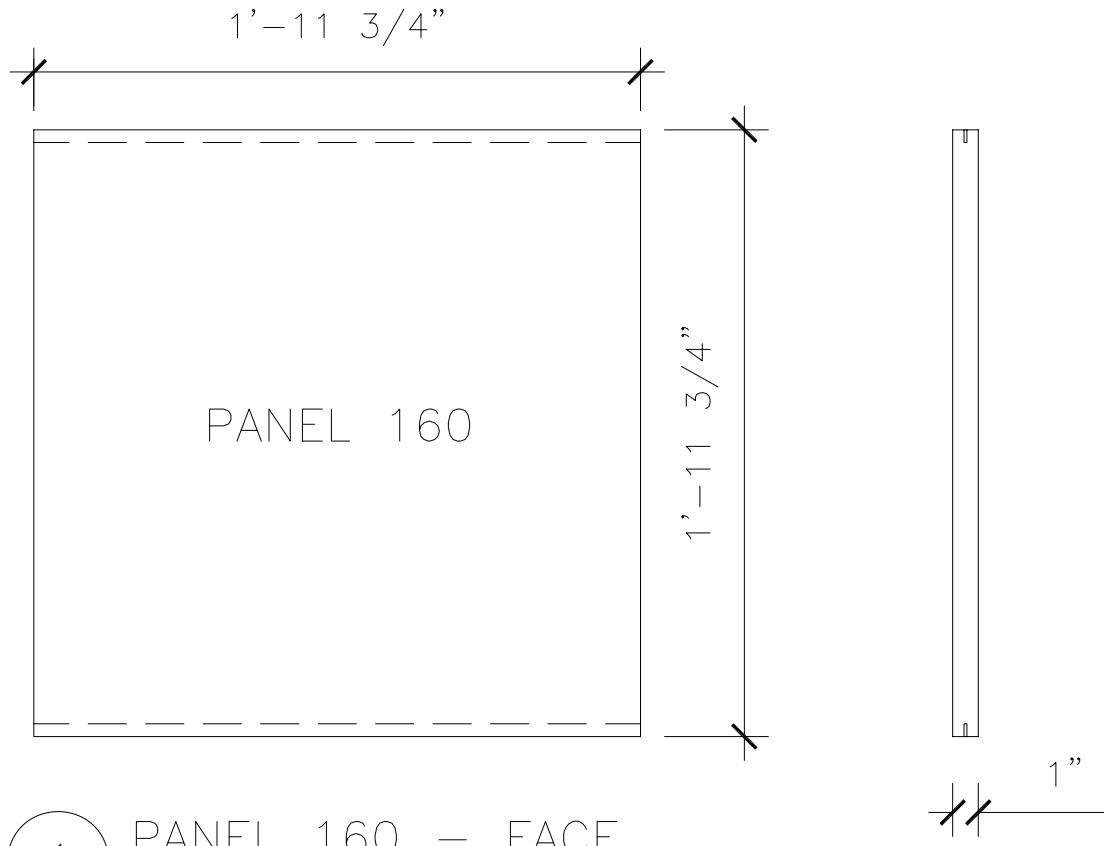

1 PANEL 160 - FACE



2 PANEL 160 - EDGE

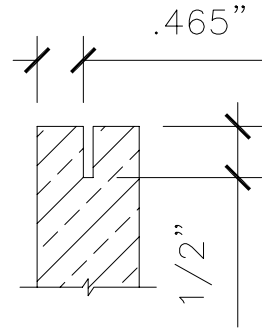

3 DETAIL-ANCHOR SLOT

AMERICAN LIMESTONE COMPANY
 A TEXAS CORPORATION
 WWW.AMERICANLIMESTONE.COM
 INFO@AMERICANLIMESTONE.COM

PANEL 160 - 24"x24" (NOMINAL)

SCALE: NTS

2.6.3



Panel 160
(see p. 2.6.3 of
ALC Solution Manual)

Staggered Corner
(see p. 2.6.6 of
ALC Solution Manual)

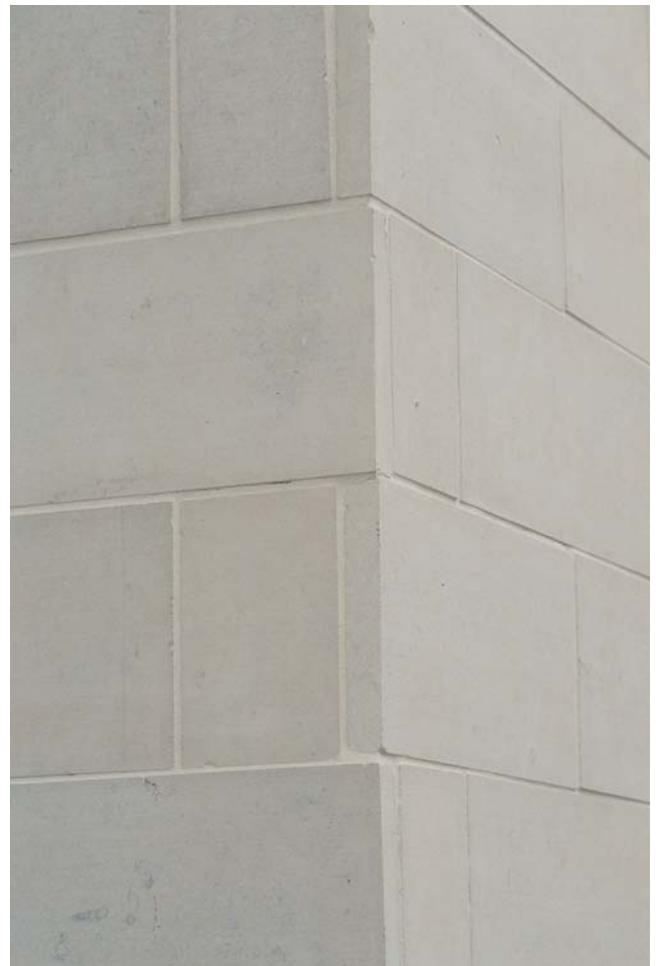

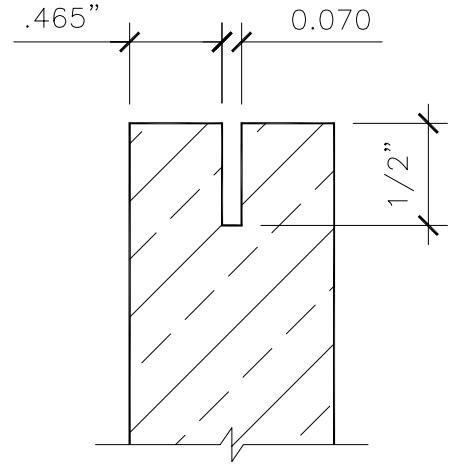
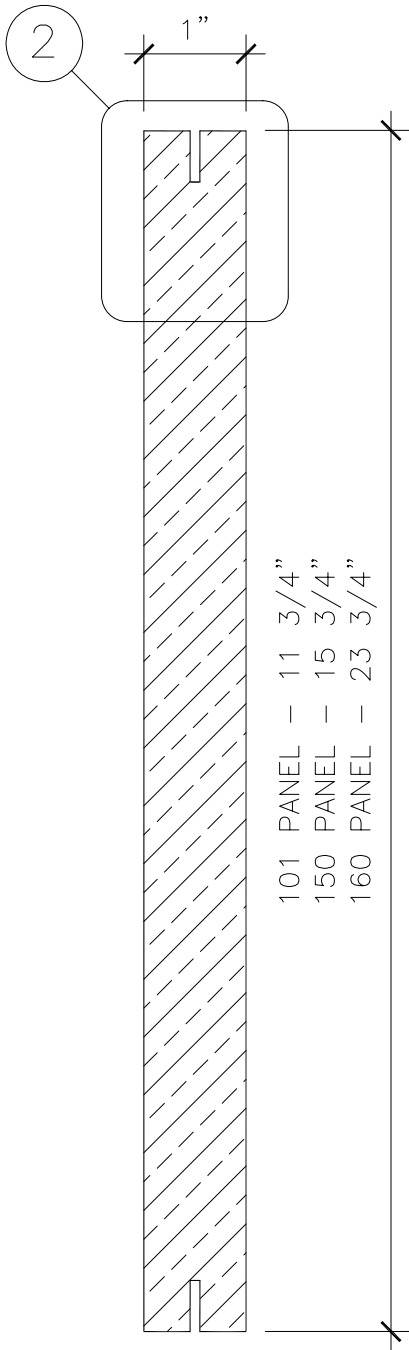

2 DETAIL-ANCHOR SLOT

1 SECTION THROUGH PANELS 101, 150 & 160

AMERICAN LIMESTONE COMPANY
 A TEXAS CORPORATION
 WWW.AMERICANLIMESTONE.COM
 INFO@AMERICANLIMESTONE.COM

PANEL SECTION - PANELS 101, 150, 160
 SCALE: NTS

2.6.4

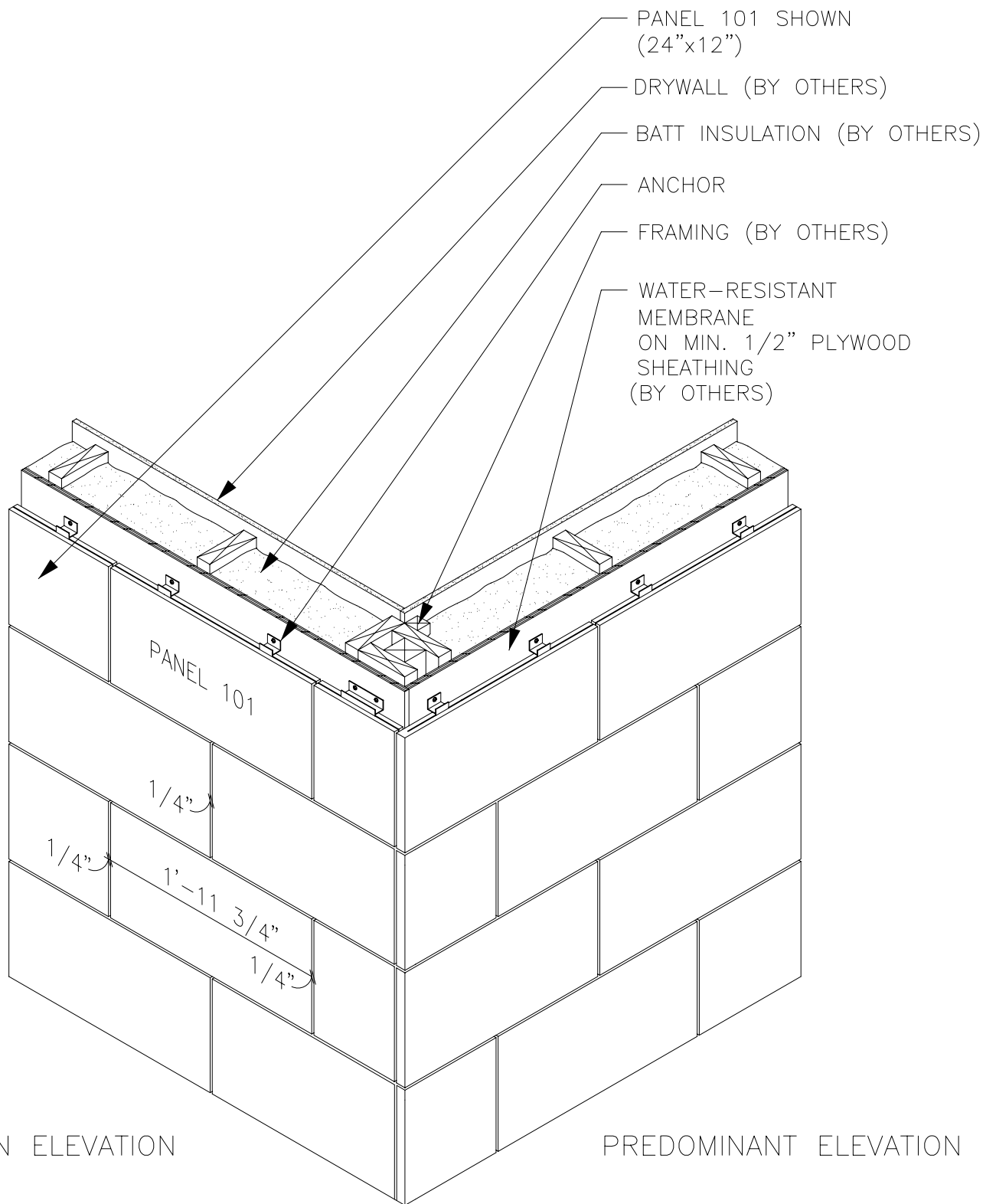

1 PERSPECTIVE OF THRU-PANEL CORNER DETAIL
PANEL 101 SHOWN

AMERICAN LIMESTONE COMPANY
A TEXAS CORPORATION
WWW.AMERICANLIMESTONE.COM
INFO@AMERICANLIMESTONE.COM

PERSPECTIVE OF THRU-PANEL CORNER DETAIL

2.6.5

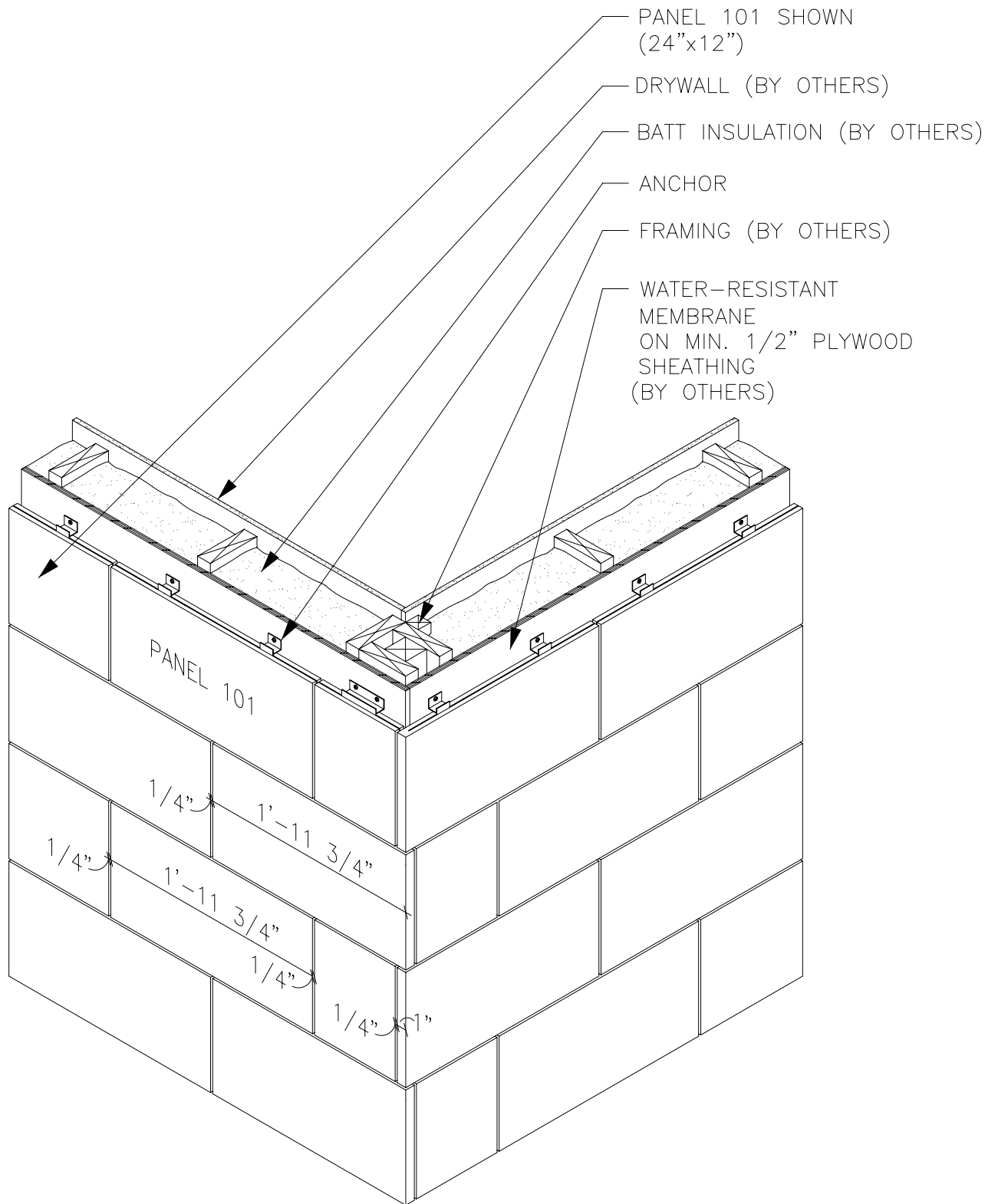

1 PERSPECTIVE OF STAGGERED CORNER DETAIL
PANEL 101 SHOWN

AMERICAN LIMESTONE COMPANY
A TEXAS CORPORATION
WWW.AMERICANLIMESTONE.COM
INFO@AMERICANLIMESTONE.COM

PERSPECTIVE OF STAGGERED CORNER DETAIL – PANEL 101 SHOWN

2.6.6

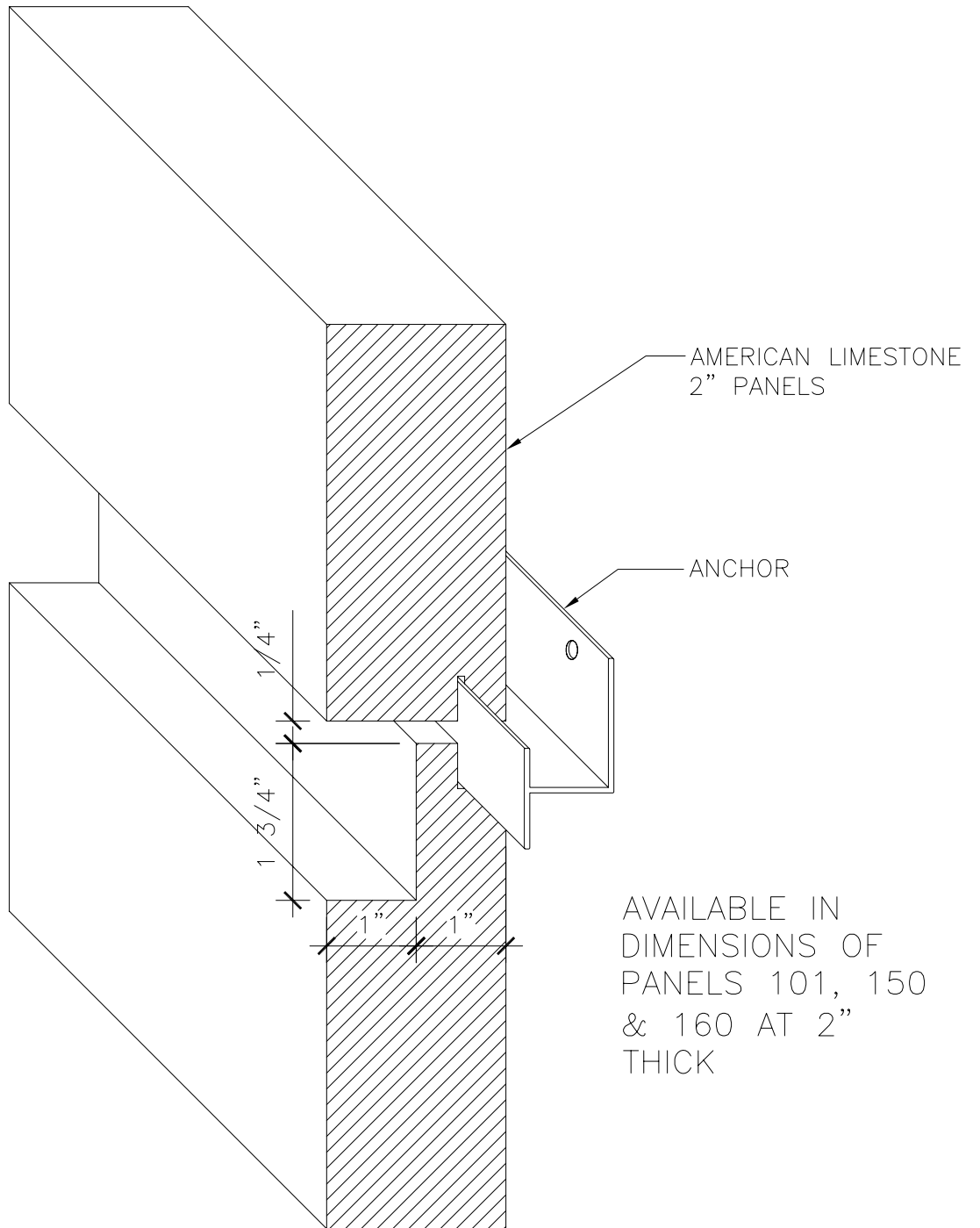

1 RUSTICATED PANEL DETAIL INTERIOR/EXTERIOR

AMERICAN LIMESTONE COMPANY
A TEXAS CORPORATION
WWW.AMERICANLIMESTONE.COM
INFO@AMERICANLIMESTONE.COM

RUSTICATED PANEL DETAIL INTERIOR/EXTERIOR

SCALE: NTS

2.6.7